

2stand-Luna

Patent Pending

NEW Illuminated Point-of-Sale Display

HOW IT WORKS

2stand-Luna gives you the chance to improve your communication via the use of illumination – for the right price.

Economical and flexible

The display is digitally printed, resulting in affordable pricing. If you want to change the graphics just replace them with a new sleeve.

Illuminated

Cut-out example shows the use of a high quality LED light column.

Fast delivery

Digital printing allows for a quick turnaround. Your display can be produced in a few days instead of weeks.



Simple to assemble

It is delivered flat and is assembled in minutes.

High image quality

Printed on high quality Polypropylene material for stunning illumination.

Simple to place

Double-sided printing is standard.

Flexible Feet

Lite and flexible. Made from shatter-proof PETG.

Versatile • Cost Effective • Re-Usable • Compact

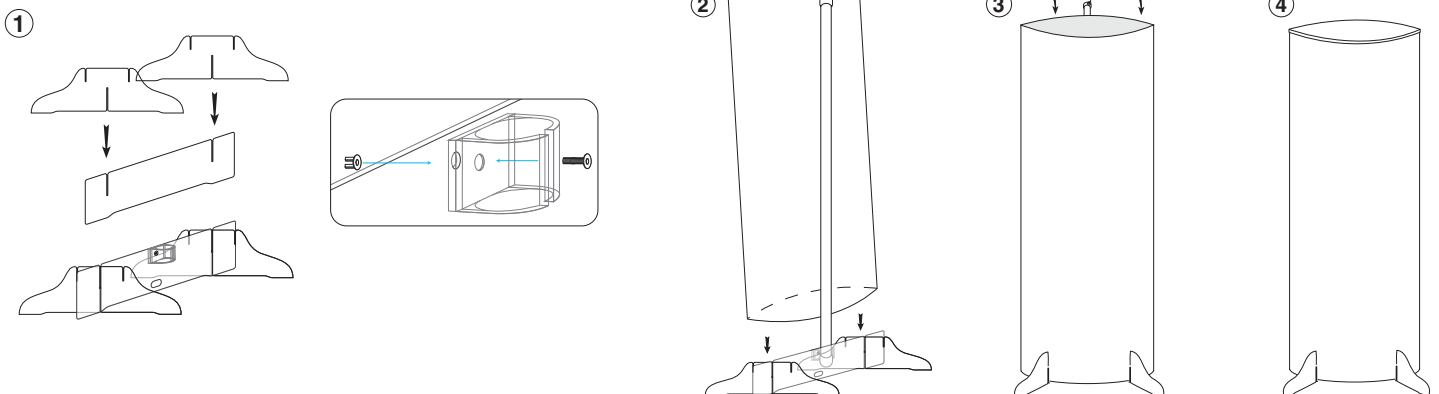

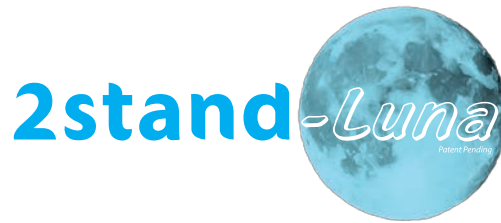

NEW Illuminated Point-of-Sale Display

THE SYSTEM

2stand-Luna is an illuminated point-of-sale display that gives you the chance to improve your communication via the use of illumination – for the right price. The display is digitally printed, resulting in affordable pricing. If you want to change the graphics just replace them with a new sleeve.

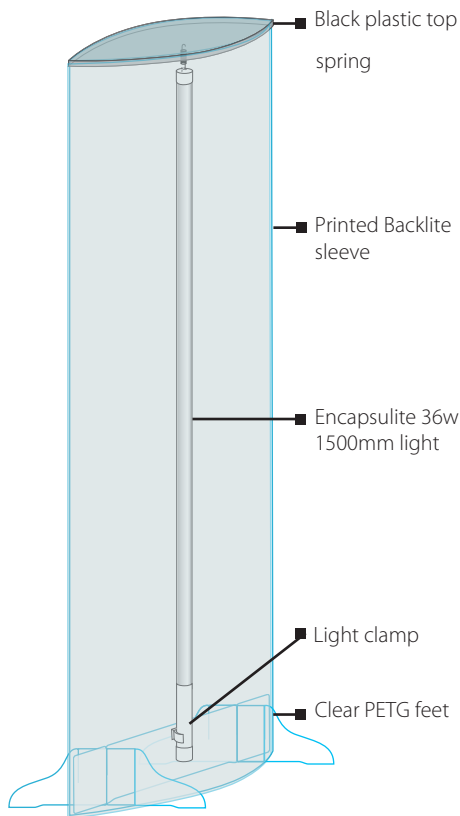

PRICES

Prices for larger quantities available on request. File handling and pre-press charges may apply. 2stand is a patented product manufactured under license by Composite Images.

| Complete Kit (Illuminated) | | Replacement Sleeves | |
|----------------------------|----------|---------------------|----------|
| Qty* | 1600mm | Qty* | 1600mm |
| 1 to 4 off | \$395.00 | 1 to 4 off | \$175.00 |
| 5 to 10 off | \$370.00 | 5 to 10 off | \$145.00 |
| 11 to 24 off | \$345.00 | 11 to 24 off | \$125.00 |
| 25 to 50 off | \$315.00 | 25 to 50 off | \$105.00 |

* Prices do not include GST.

TRADE ENQUIRIES WELCOME

